



Z891

TRENCH DRAIN SUPPLY

877-903-7246

www.trenchdrainsupply.com

2-1/4 [57] WIDE REVEAL BY 60 [1524] LONG STAINLESS STEEL SLOTTED CHANNEL

TAG _____

Dimensional Data (inches and [mm]) are Subject to Manufacturing Tolerances and Change Without Notice

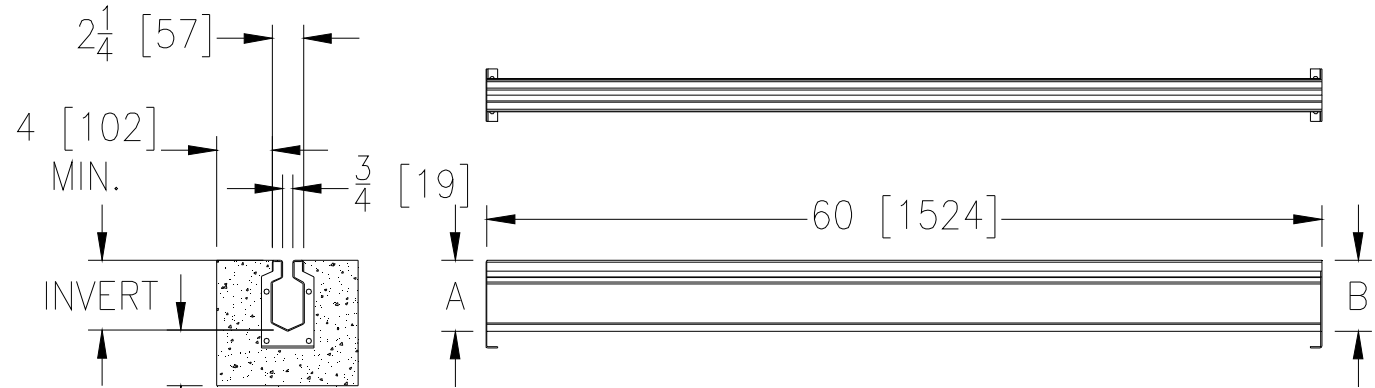

SPECIFYING ENGINEER IS RESPONSIBLE FOR CONCRETE ENCASEMENT AND REINFORCING BASED UPON APPLICATION AND LOCAL CODES

ENGINEERING SPECIFICATION: Zurn Z891

Channels shall be 60 [1524] long, 3/4 [19] wide slot and have a 2-1/2 [64] throat. Modular channel sections shall be made of 16ga. fabricated Stainless Steel conforming to ASTM A-240 (type 304). Channels shall have a bolted, flanged connection between channel sections that will not separate during the installation, gaskets available. Channels shall weigh less than 2 lbs. [.91kg] per linear foot, have a smooth, radiused self cleaning bottom with a Manning's coefficient of .009 and 1.04% or neutral 0% built in slope. Channels shall have feet for patty pour or leveling studs standard to secure trench in its final location. Channels shall be produced in the U.S.A.

Table with columns: Trench No., Shallow Invert, Deep Invert, and FLOW (LPM, GPM, LPS). Rows 89101 to 89110.

PREFIX OPTIONS (Check/specify appropriate options)

___ Z Five-Foot Stainless Steel Slotted Trench Drain with bolted flange connection*

SUFFIX OPTIONS (Check/specify appropriate options)

Outlet Adapters Add/Each

- ___ -E1 Closed End Cap
___ -E2 2 [51] No-Hub End Outlet
___ -U2 2 [51] No-Hub Bottom Outlet

Miscellaneous Options

- ___ -K Waterproofing Flange
___ -KC Pan and Clamping Collar with Weep Holes

Table with revision information: REV. I, DATE: 10/18/12, C.N. NO. 124852, DWG. NO. 64022, PRODUCT NO. Z891

*REGULARLY FURNISHED UNLESS OTHERWISE SPECIFIED